

# The Professional Electronic Spinner

Please read these instructions carefully before using your new spinner.

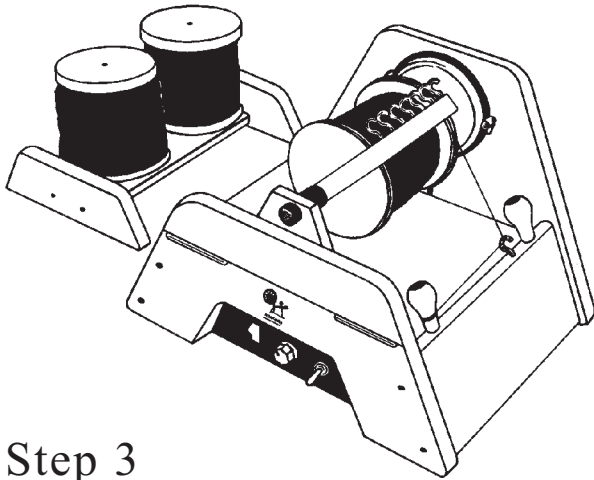

## Step 1

Thread the yarn guide hooks into the flyer arms. A little candle wax on the threads will make this easier.

## Step 2

Unlatch and lower the front flyer bearing. Slide a bobbin onto the flyer shaft and locate the shaft into the motor coupling. **Note:** the slot must locate onto the pin in the coupling.

## Step 3

Take the brake band (we have provided both cord and nylon brake bands to choose from) and measure 47cm and cut (put this piece aside). Take the smaller piece and thread it through the hole in the tension knob and tie a knot. Locate the tension knob into the front hole of the side.

## Step 4

Fold the front flyer bearing up and locate the flyer orifice into the bearing at the same time.



Please note: it is most important to ensure the latch is locked down before starting the motor. If not, the front flyer bearing can fall forward and release the flyer which can cause damage if it is revolving at speed.

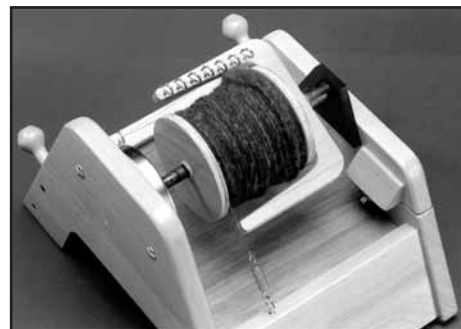

## Step 5

Take the remaining piece of brake band (the piece that measures 47cm) and tie one end onto a tension spring. Tie the other end onto the remaining tension spring. Now join the tension spring with the brake band on the tension knob. It should look like this:

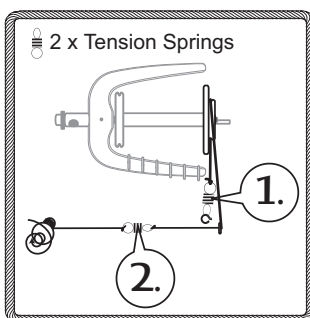

## Step 6

Locate the threading hook into the rear hole in the right hand side.

## Step 7

Locate the two steel pins into the holes in the Lazy Kate.

**Note about the brake band:** To increase the life of the brake band, rub candle wax along it. If it wears out, simply replace it with another piece of waxed cotton string. Do not extend the spring more than twice its own length.

## Accessories

Your spinner maybe connected to a 12 volt DC System such as a car cigarette lighter or caravan system by using the input socket in the rear of the spinner. Suitable plugs and cords are available from electrical stores or through your Ashford dealer.

## Lubrication:

We recommend Ashford Spinning Oil be applied regularly to the front flyer bearing and bobbin bearings. A drop of heavy grease or vaseline may be applied to the motor coupling to make bobbin changing easier and reduce noise. The bobbin and flyer must revolve freely and independently of each other.

## Controls:

- A) The right hand switch starts and stops the motor.
- B) The middle dial controls the motor speed. **Please note** that under most circumstances you will only be using about 10—20% of the motor's potential speed. However when spinning very fine fibres a higher flyer speed is required or when spinning a thick yarn the motor requires more power to twist the extra fibres. It is **not** recommended to run the motor and flyer at full speed unless you are spinning as there is the dangerous possibility of the flyer, which is made of wood, breaking due to the high centrifugal forces acting on it.
- C) The left hand switch has two positions, forward or reverse, clockwise for spinning and anti-clockwise for plying. Do not reverse the direction of the motor without first stopping it with the **ON/OFF** switch.

## Safety:

Your Professional Electronic Spinner can be altered to accept either 110—120 volts or 220—240 volts. Check to ensure you have the correct voltage mains supply for your new spinner and if necessary reset the switch on the back. Always unplug your spinners when not in use. Do not leave your spinner without first switching it off with the **ON/OFF** switch. Never open the electronic compartment without first disconnecting it from the power supply. Do not use your spinner in damp or wet conditions.

## Spinning:

Tie a piece of yarn about 1 metre (1 yard) to the bobbin and thread it around the yarn guide hooks and through the orifice. Have your prepared fibres handy ready to spin. Position the direction switch onto **forward**. Twist the speed controller anticlockwise until it stops. Turn the power switch **on** and twist the speed controller clockwise until the flyer starts revolving at a speed you feel comfortable to spin at. Allow the yarn to feed on and commence drafting the prepared fibres. You will note that the flyer speed will vary with different brake band tensions. This is normal and easily corrected by resetting the speed control.

Once the brake tension and speed control have been adjusted to suit your spinning technique little further adjustment should be required. When stopping to move the yarn to the next yarn guide switch the motor off on the **ON/OFF** switch rather than the speed control. This will ensure you continue at the same flyer speed as before and result in more consistent yarn.

To change bobbins simply switch off the motor, remove the brake band from the bobbin, unlatch the front flyer bearing and tilt it forward. Remove the flyer from the coupling and change bobbins. Remember to check that the latch is **locked down** after the flyer is back in place.

After 15 minutes or more of spinning you may notice the base of the control box warming up. This is normal and is a result of the transformer dissipating heat through the metal.

We trust your new **Professional Electronic Spinner** will enhance the pleasure you receive from your pastime and that it will enable you to become more creative and productive.

## Orifice Reducer Bush:

A nylon bush that may be inserted into the flyer orifice to reduce the diameter is included in the kit. This is beneficial when spinning finer yarns as it will help prevent the yarn vibrating. By spinning the yarn at about a 45 degree angle to the orifice the vibration will almost be eliminated. When plying or spinning thick yarns, remove the bush.

## Blowing Fuses:

Should the fuse blow replace it with a **1 Amp Fuse**.



415 West Street, P.O.Box 474, Ashburton, New Zealand  
Telephone (64-03) 308 9087 Facsimile (64-03) 308 8664  
E-mail sales@ashford.co.nz Home Page <http://www.ashford.co.nz>

