

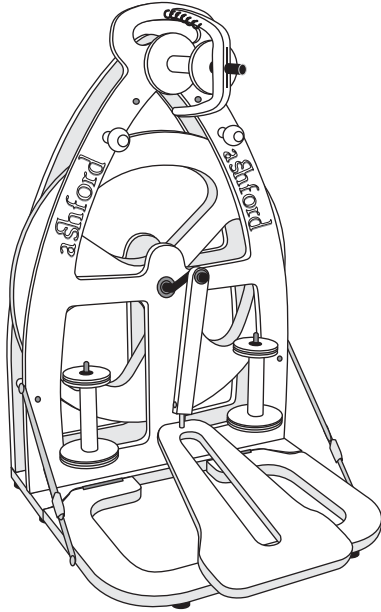

Another quality product from Ashford Handicrafts.

# The Joy Ashford Spinning Wheel Assembly and Spinning Instructions



Dear Spinner

Congratulations on purchasing your new Joy Ashford Spinning Wheel. This wheel is named after my mother Joy who with Walter Ashford founded our company over 60 years ago. Over this time our family have continued to develop and refine our range of spinning wheels and weaving looms. There are now over 450,000 Ashford spinning wheels in use around the world. We are delighted to now bring you the Joy knowing it will become a lifetime companion to you. Thank you for choosing Ashford.

Happy Spinning.

Richard Ashford

\*The veneered customwood has been lacquered prior to assembly. If desired the application of **Ashford Wax Finish** may further enhance its appearance.

## Parts

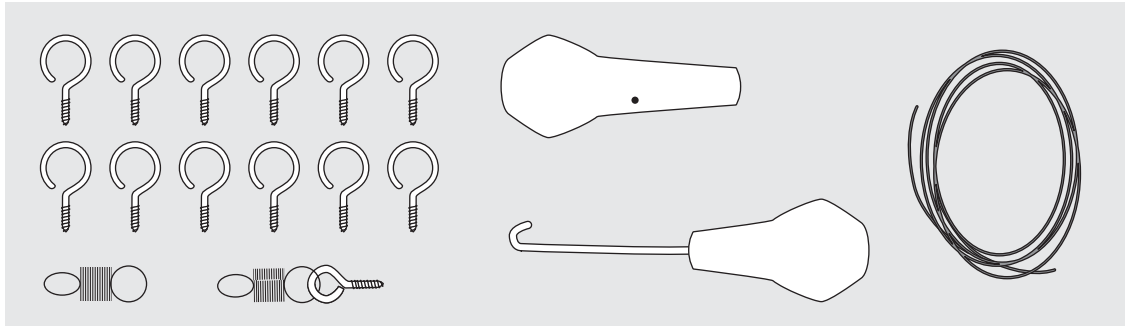

## Step 1

Disengage the latch on the right hand side of the frame.

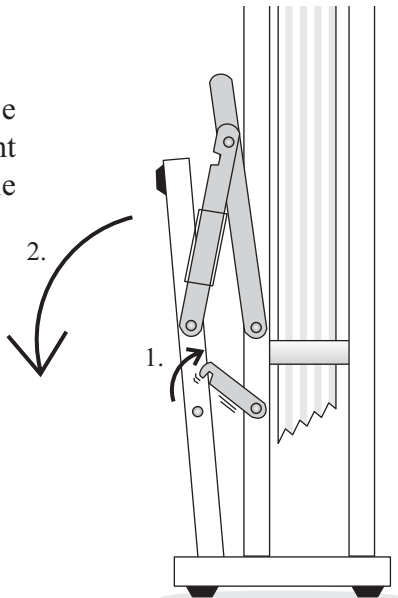

## Step 2

Fold the treadle down and lock the tubes into position. The clear tubes may be slid up the stays for extra

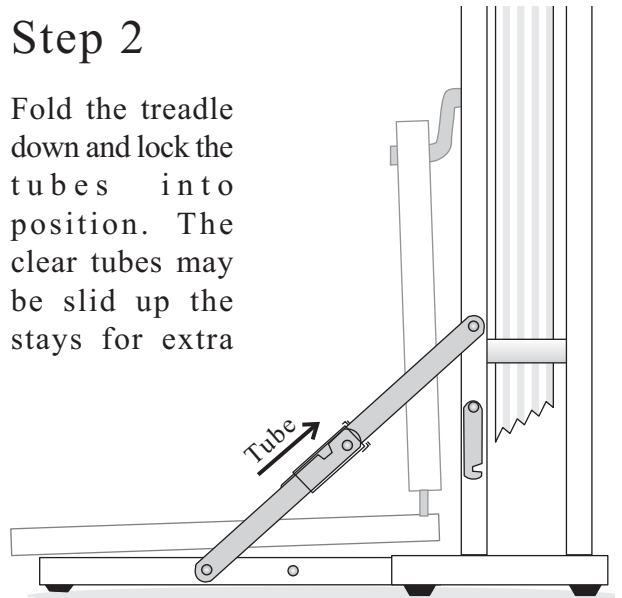

### Step 3

Thread 12 flyer hooks into the pre-drilled holes in the flyer.

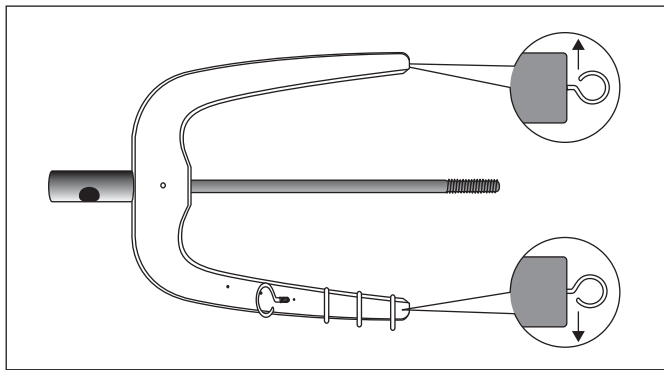

### Step 4

Thread the screw eye with the brake band spring attached in to the pre drilled hole in the front frame.

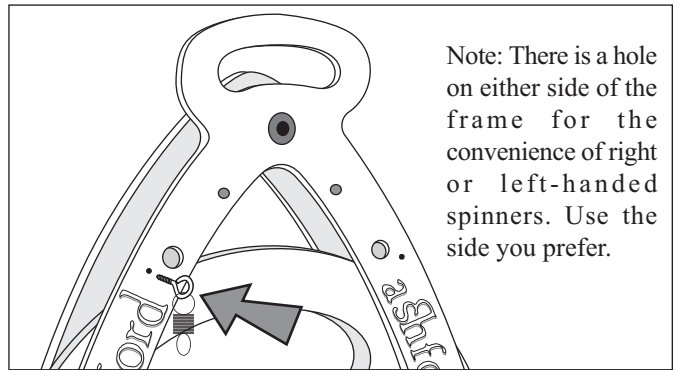

### Step 5

Place a bobbin on the flyer shaft. It is convenient to oil the bearings now. Thread the flyer shaft into the flyer drive shaft. Hold the flyer whorl with one hand and rotate the flyer clockwise with the order. Take care not to force or overtighten the flyer.

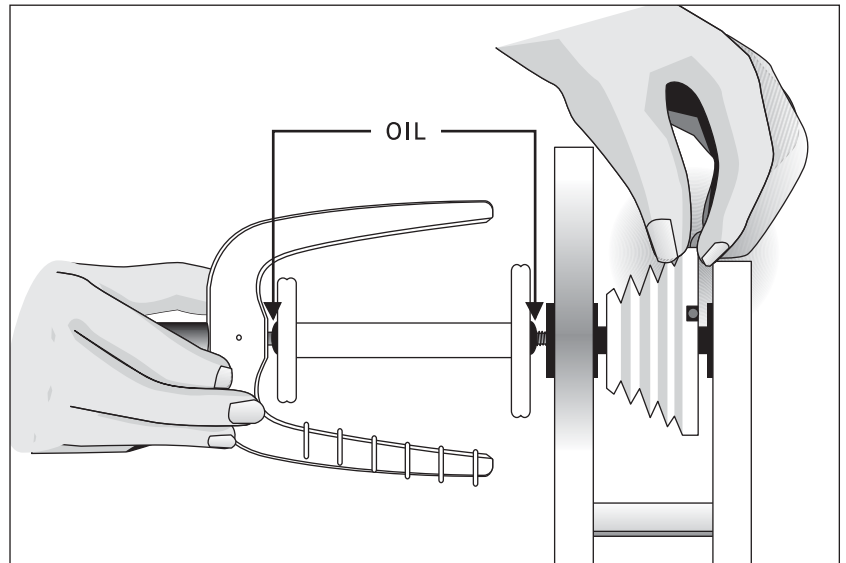

### Step 6

Cut 30cm (12") off the brake band. Tie one end to the spring attached to the frame (Step 4) and the other to the second spring so that you have 22cm (8 3/4") in-between the 2 springs. (30cm is the approximate length of this page).

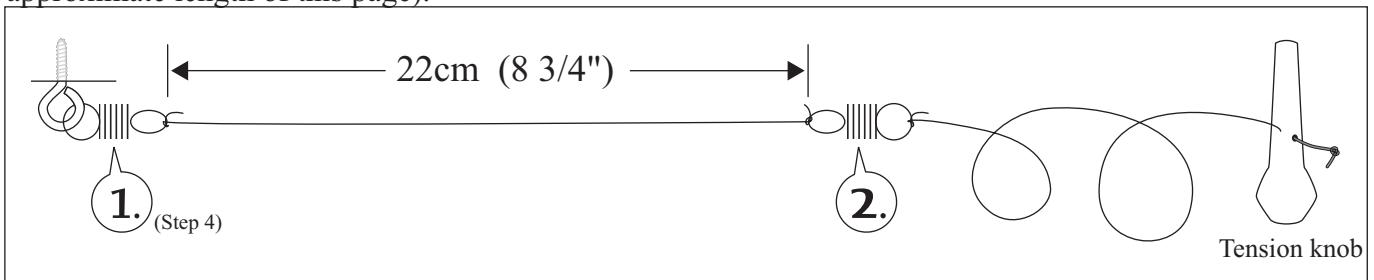

### Step 7

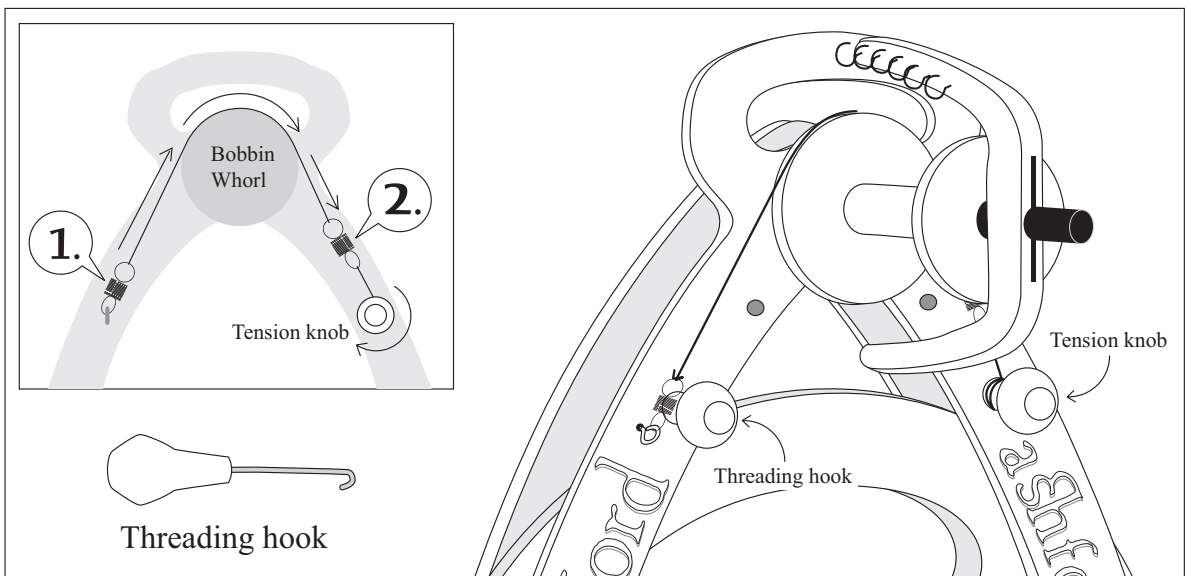

## Step 8

Locate the two spare bobbins onto the bobbin holders in the front frame. When plying or spinning bring the bobbins forward. Push them back before folding the treadle up.

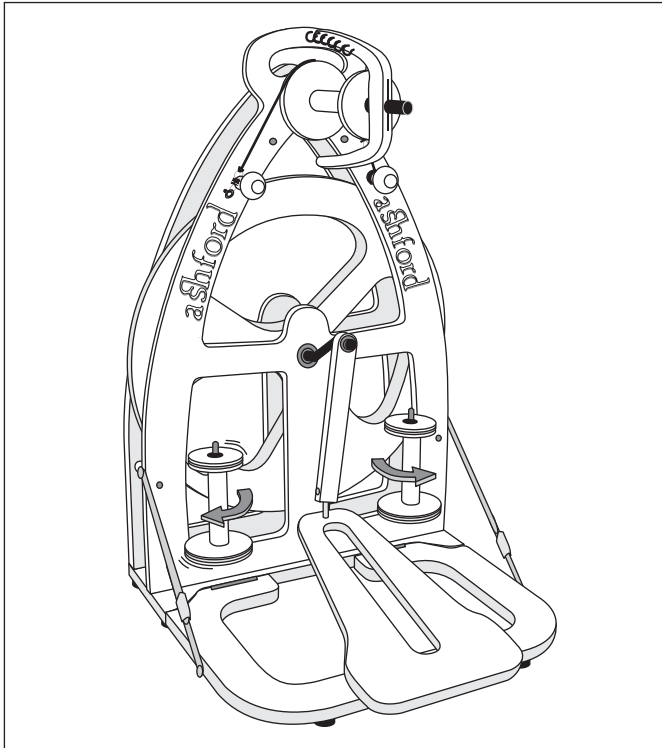

## Ratios

Position the stretchy drive cord around the smallest groove in the wheel and then over the largest flyer whorl. This gives a flyer to wheel ratio of 6:1. The other ratios are 8,11&14:1. When changing ratios ensure the drive cord directly aligns the wheel and flyer whorl. When spinning coarse fibres or thick yarns use the slow flyer speed of 6:1. For fine fibres and yarns use a faster flyer speed.

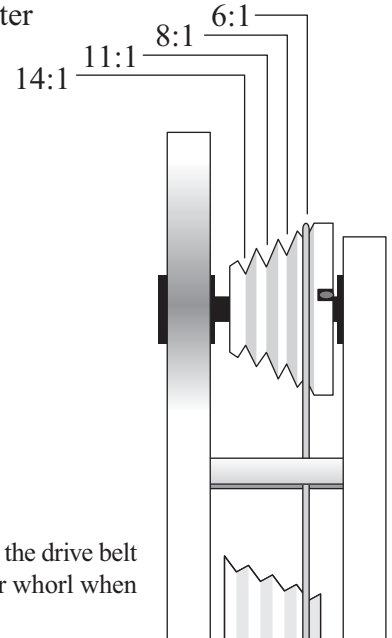

\*Release the tension on the drive belt by taking it off the flyer whorl when not in use.

## Folding up your Spinning Wheel

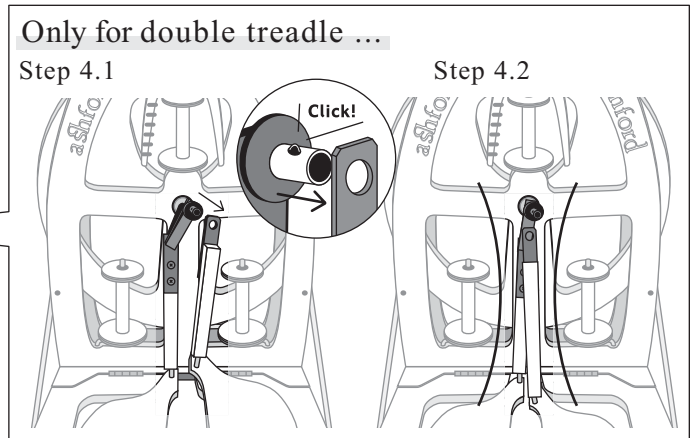
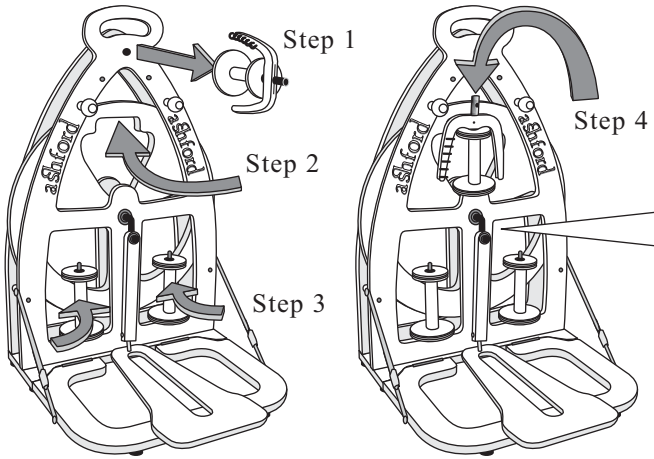

Your spinning wheel is now ready to transport. Always carry it by the built in handle or in the optional Shoulder Bag.

\*Do not carry it by the flyer which could bend if handled roughly.

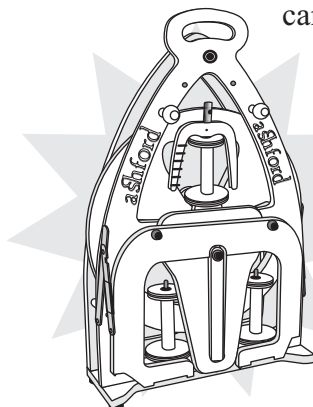
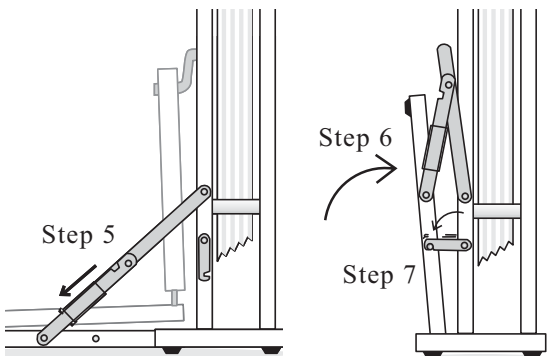

Option

# You are now ready to start spinning

## Step 1

Tie a piece of yarn called a leader, about one meter (1 yard) long, on to the bobbin and warp it around the bobbin several times to prevent it slipping. Thread the leader yarn around the flyer hooks and through the orifice.

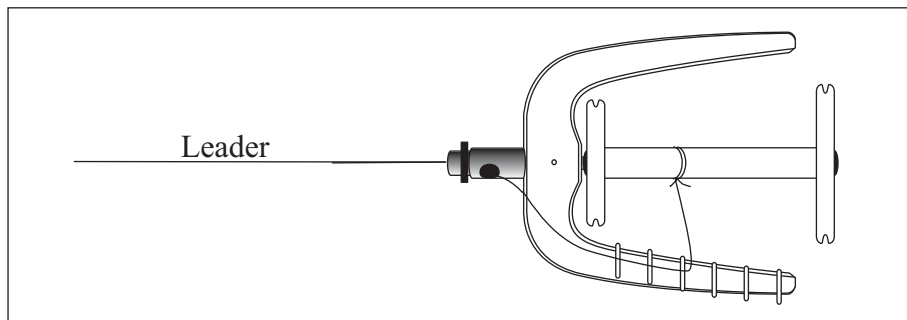

## Step 2

Adjust the tension knob so that the brake band spring is only just starting to extend. Too much tension will make treading harder.

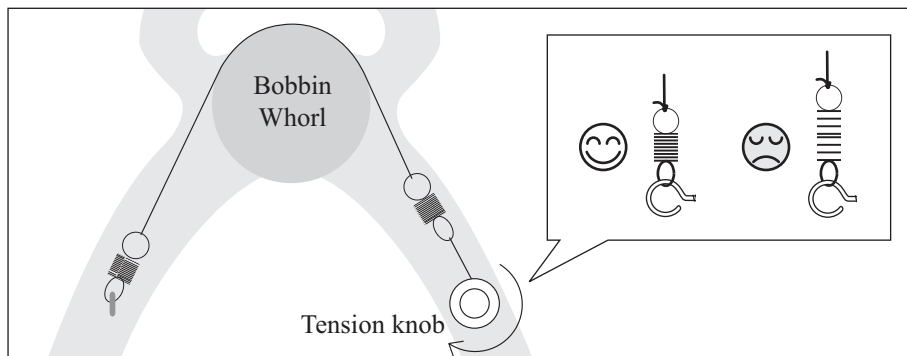

## Step 3

Sit in comfortable posture. A straight back **Ashford Spinning Chair** is ideal. Treadle with either foot or both together. One foot or two feet is OK.

## Step 4

Try treading slowly clockwise. Position the wheel with the crank at 1 o'clock and push down. The weighted wheel and heel and toe treadle action make this easy.

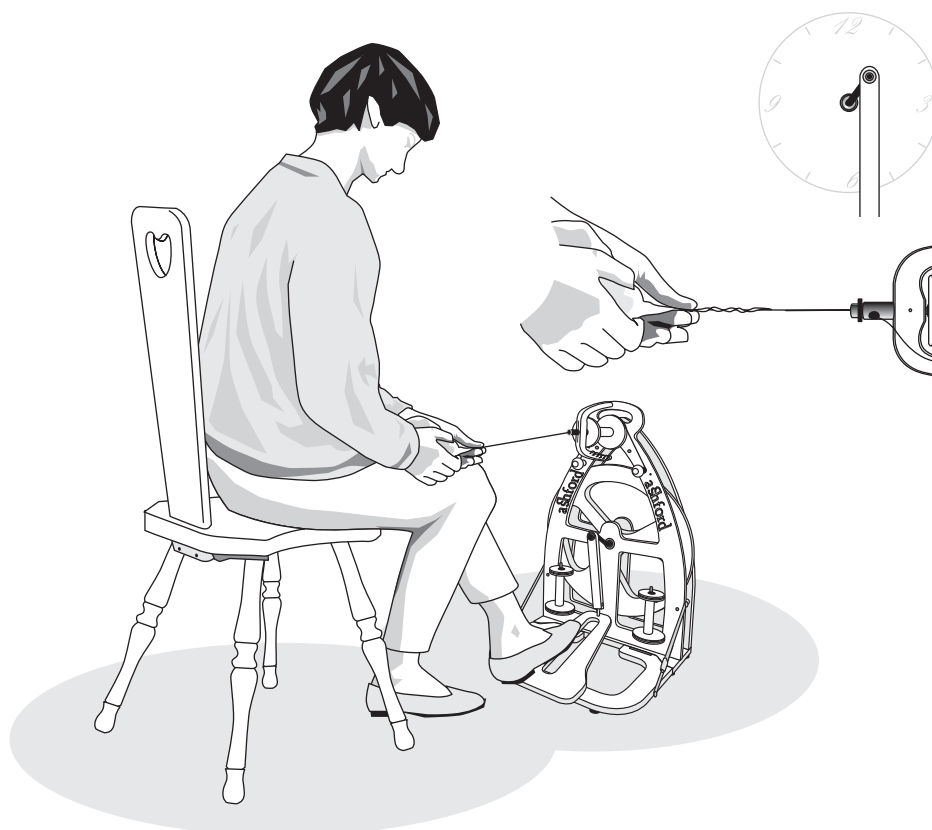

## Step 5

Join your prepared fibres onto the leader and now you are spinning singles. Take more fibre and start spinning - don't treadle too first.

## Step 6

To ply two singles together, place two bobbins of single ply yarn on the two bobbin storage pins. Tie these two yarns onto the leader. Position the wheel with the crank at 11 o'clock and treadle the wheel anticlockwise.

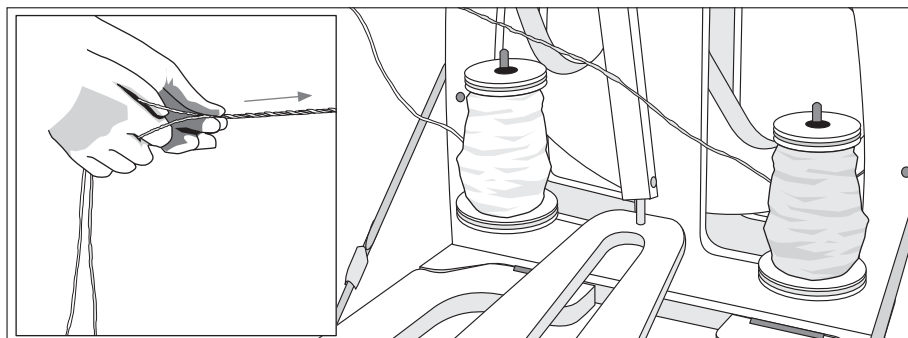

\*For future spinning information refer to "The Ashford Book of Spinning", a 152 page book full of ideas and inspirations for spinners.

# Maintenance

## Lubrication

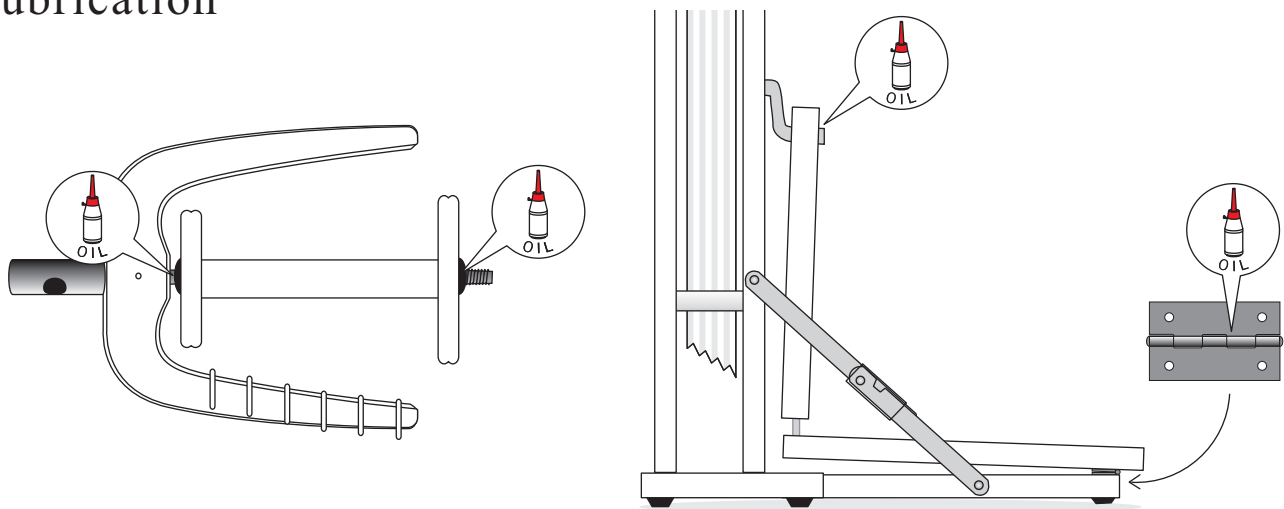

## Replacing a broken or worn drive belt

### Step 1

Take these 10 screws out.

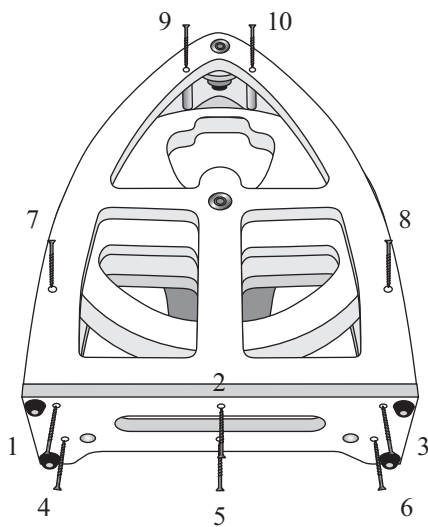

### Step 2

Slide new band in place.

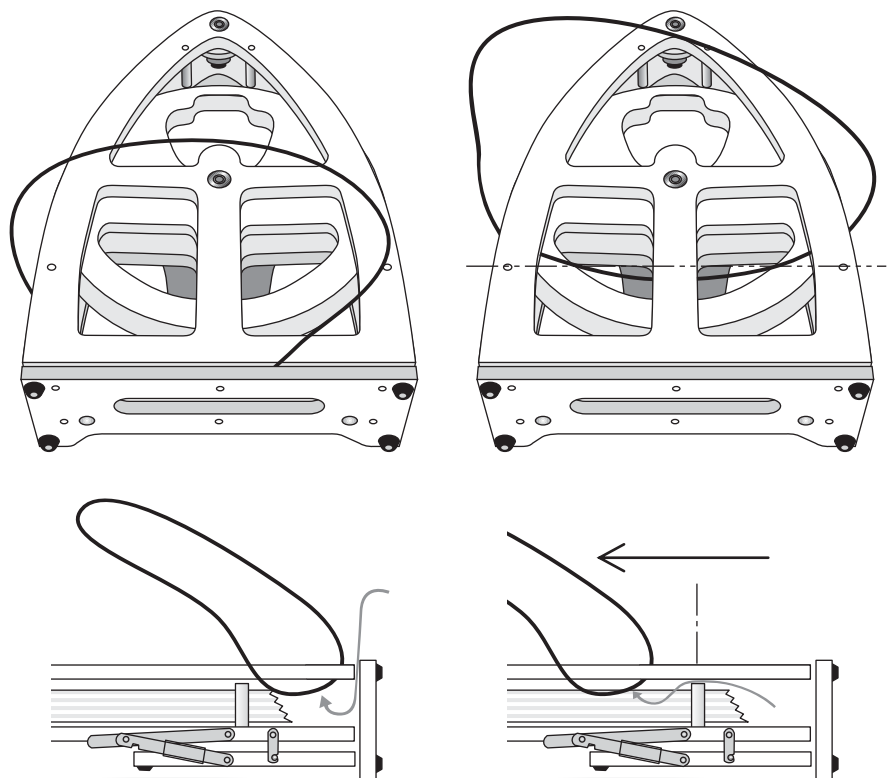

### Step 3

Tighten all screws.

